



Full Tank

HYDRAULIC SWING GATE OPERATOR FOR CONDOMINIUM / INDUSTRIAL USE FOR LEAF LENGTHS UP TO 7 M / 23 FEET



- SEA Total Quality: all parts are manufactured and tested in-house
- The **hydraulic system grants high and long term performances**
- **Oil lubrication** of all mechanical components
- Anti crushing guaranteed through by-pass valves for max. thrust adjustment
- 10,63 inches or 15,35 inches stroke (FULL TANK LARGE)
- Standard, oscillating aluminium fork back fixing
- **Hydraulic distributor made from aluminium extrusion**
- Version with separate piston and hydraulic unit, available on request FULL TANK SP
- Electronic reversing sensor available (on request)
- Canceled positive stops
- 20 mm rod diameter
- Duty cycles* : 70 per hour

* Duty Cycles depend on gate size and installation



Release system protected by metal lock with release key at the inside.



Release with metal lock protection



Round joint bearing for stroke adjustment



On request versions with hydraulic slowdown for a smooth approach of the leaves in closing

CODE	NAME	MAX LEAF WEIGHT	MAX LEAF LENGTH	MAX OPENING DEGREE	MAX CYCLES/HOUR	PCS PER PALLET
106AC3S0-1-CSA	FULL TANK AC	2200 lbs	20 feet	120°	70	40
106AC3S0-CSA	FULL TANK AC BRAKE	2200 lbs	20 feet	120°	70	40
107SB2S0-CSA	FULL TANK SB LARGE SLOW BRAKE	2200 lbs	23 feet	120°	70	25
on demand	FULL TANK EXTRA LARGE	2200 lbs	25 feet	120°	70	25

CONTROL BOARDS

CODE	DESCRIPTION
2302A110G2DG	GATE 2 DG 110V with plastic enclosure
2302A110G2DGPW	GATE 2 DG 110V PRE-WIRED with metal enclosure 3R (21"x11"x5")
2302A220G2DGR	GATE 2 DG 220V Replace (only circuit)

MODEL	A	B	C
FT	40,35 in	38,58 in	10,63 in
FT with brake	41,73 in	39,37 in	10,63 in
FT LARGE	50,00 in	47,83 in	15,35 in
FT LARGE with brake	51,37 in	48,82 in	15,35 in

FT EXTRA LARGE : C 19,68 in

* GATE 2 DG PRE-WIRED: GATE 2 DG + Loop Module + Electric Switch + Plugs + Metal Enclosure (21"x11"x5") + 2 Plug-in Loop (see specs page 59)
On request different dimensions

ACCESSORIES



12715105-CSA
PS270
Positive stops
(FULL TANK / FULL TANK BRAKE)
Kit mechanical stop



12715110-CSA
PS390
Positive stops
(FULL TANK LARGE / FULL TANK LARGE BRAKE)
Kit mechanical stop



23105019
PROBE
kit probe to manage low temperature (card LE+ cable 6 feet -1,8 m)



16700047
G-LOCK
Magnetic Lock

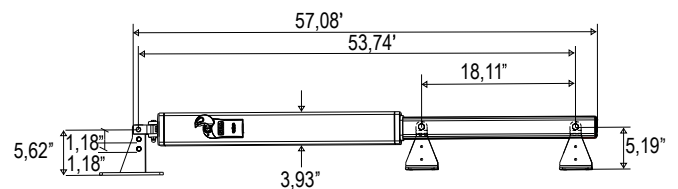

Dimensions (inches)

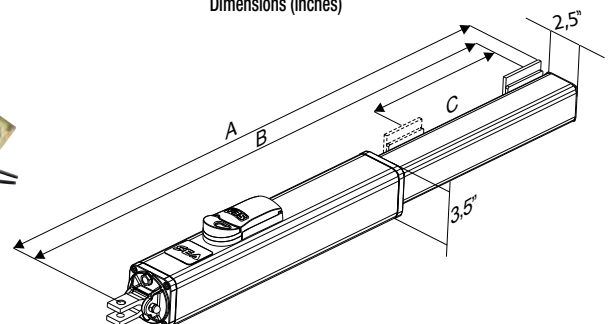

OIL
Green oil in 1 quart bottle



12715070
BRA
Adjustable back bracket to screw n.2 pcs



23105053-1
STAR 500
Battery back-up for AC motors 110V



16700060
LOCK KIT 12V
Electric lock Counter-plate for horizontal or vertical mounting external and internal cylinder



For leaf length over 6 feet an electric or magnetic lock is recommended